

Bio Pharm Fittings and Adapters



Bio-Ease® Clamps | True Unions | SaniSure® Clamps | Gaskets | Diaphragms | Hose Clamps | aSure® Adapters | Mono Barb
Classic Fittings | Elbows | Tees | Short Bull Tees | Concentric Reducers | Eccentric Reducers End Caps | Pipe | Spool Pieces
Sight Gauges | Over-Molded Hoses | Point of Use Samplers | Filling Bells | Tube Weights | Gamma Stable Stir Bars | Pinch Clamps

Authorized Distributor:
Acuity Process Solutions
Web: acuityprocess.com
Phone: 508.809.5099



What Differentiates Our Fitting Program

Single use biopharmaceutical processes continue to evolve, so does the need for a wider array of unique fluidic components.

As an early and well-established developer of single use sanitary components, we have deep experience from years of listening to and learning from our customers. As a result, we have become a leader in sanitary non-metallic fittings. We produce one of the widest ranges available from a sole source. Many of our fitting styles can only be found within our program. We will continue to invest in our customers by developing hard-to-find fitting solutions.

Compliance

We engineered our entire line of sanitary fitting connections to be ASME-BPE compliant. All source materials are medical grade and meet US and EU standards for use in pharmaceutical process environments.

Security of Supply

We operate two injection molding facilities in North America. We have the ability to manufacture many of the same style fittings in both locations, which ensures security of supply.

Selection

We offer a wide array of fitting styles, materials and package configurations not found anywhere else.

Inventory

We stock most of what we offer. In the case of large volume usage customers, we manage your cash-flow and inventory by utilizing our "Just in Time" blanket program.



Regulatory Information

Resin Name	Material	Material Ref#	Product Contact	DMF Listed	USP Class VI	ISO 10993	E&L Profile available	Animal Derived Ingredient /component Free (ADIF / ADCF)	TSE/BSE Compliant*
Random Copolymer (PP) FH P5M6K-80	Random copolymer (PP)	①	Yes	Yes	Yes	Yes	Yes	Yes	N/A
KYNAR® 720 (PVDF)	PVDF	②	Yes	Yes	Yes	NT	NT	Yes	N/A
CPO-3003/80	Platinum Cured Silicone	③	Yes	Yes	Yes	Yes	NT	Yes	N/A
Polysulfone® (UDEL)	Polysulfone	④	Yes	No	Yes	Yes	Yes	Yes	N/A
Polycarbonate Lexan® HPS9NEU	Polycarbonate	⑤	Yes	Yes	Yes	Yes	Yes	Yes	N/A
ZYTEL (nylon glass filled)	Nylon	⑥	No	No	Yes	NT	NT	Yes	N/A
HFB/ Cleargreen®	PVC	⑦	Yes	No	Yes	Yes	Yes	Yes	N/A
Pharma-Line I®	TPV	⑧	Yes	No	Yes	Yes	Yes	No	Yes
HYTREL®	TPE	⑨	Yes	No	Yes	Yes	NT	Yes	N/A
Polypropylene Copolymer® PF7531	Polypropylene	⑩	Yes	Yes	Yes	NT	NT	Yes	N/A
Cellgyn® (TPE)	TPE	⑪	Yes	No	Yes	Yes	Yes	Yes	N/A
Polypropylene HS Natural NAV020 WM	Polypropylene	⑫	Yes	No	Yes	Yes	NT	Yes	N/A
EPDM	Ethylene Propylene Diene Monomer	⑬	Yes	No	Yes	Yes	NT	Yes	N/A

*Notes

Some resin manufacturers employ trace levels of additives in the resin formulation, these additives may be manufactured using animal tallow as a starting substance ("tallow-derivatives"). The tallow may have been sourced from bovine species or, rarely from non-TSE relevant species. Bovine tallow-derivatives are considered low risk material for TSE/BSE as per the current revision of the U.S. Code of Federal Regulations, Title 21 Part 189.5 Substances Prohibited from Use in Human Food; Sub part B: Prohibited Cattle Material: Paragraph a7. Furthermore, the European Medicines Agency's (EMA) Committee for Medicinal Products for Human Use (CHMP) 'Note for guidance on minimizing the risk of transmitting animal spongiform encephalopathy agents via human and veterinary medicinal products' (EMA/410/01 Rev 3, 2011), and other international guidelines, state that they are unlikely to be infectious if rigorously processed during their manufacture (e.g., hydrolysis or transesterification, at not less than 200 °C under pressure for not less than 20 minutes). Our suppliers have stated that their raw materials have been processed under conditions at least as rigorous as these.

Sterilization Methods













Resin Name	Material	Material Ref#	Autoclave	Gamma Irradiation	X Ray	ETO
Random Copolymer® (PP) FH P5M6K-80	Random copolymer (PP)	①	Yes	Yes	NT	Yes
KYNAR® 720 (PVDF)	PVDF	②	Yes	Yes	Yes	Yes
CPO-3003/80	Platinum Cured Silicone	③	Yes	Yes	NT	Yes
Polysulfone® (UDEL)	Polysulfone	④	Yes	Yes	NT	Yes
Polycarbonate Lexan® HPS9NEU	Polycarbonate	⑤	Yes	Yes	Yes	Yes
ZYTEL® (nylon glass filled)	Nylon	⑥	Yes	Yes	NT	NT
HFB/ Cleargreen®	PVC	⑦	No	Yes**	NT	Yes
Pharma-Line I	TPV	⑧	Yes	Yes	NT	Yes
HYTREL®	TPE	⑨	Yes	Yes	NT	Yes
Polypropylene Copolymer PF7531	Polypropylene	⑩	Yes	Yes	NT	NT
Cellgyn® (TPE)	TPE	⑪	Yes	Yes	NT	Yes
Polypropylene® HS Natural NAV020 WM	Polypropylene	⑫	Yes	Yes	NT	Yes
EPDM	Ethylene Propylene Diene Monomer	⑬	Yes	NT	NT	Yes

Notes

NT=Product not tested

**= Not Recommended Over 40 kGy

Resin Properties

Resin Name	Material	Material Ref#	Transparency	Max Use Temp (°C)	Brittleness Temp (°C)	Recycling Symbol
Random Copolymer® (PP) FH P5M6K-80	Random copolymer (PP)	①	Translucent	135	0	
KYNAR® 720 (PVDF)	PVDF	②	Translucent	135	-62	
CPO-3003/80	Platinum Cured Silicone	③	Clear	210	-55	
Polysulfone® (UDEL)	Polysulfone	④	Translucent	149	-100	
Polycarbonate Lexan® HPS9NEU	Polycarbonate	⑤	Translucent	135	-135	
ZYTEL® (nylon glass filled)	Nylon	⑥	Opaque	150	-40	
HFB/ Cleargreen®	PVC	⑦	Clear	70	-30	
Pharma-Line I®	TPV	⑧	Opaque	135	-59	
HYTREL®	TPE	⑨	Opaque	130	-40	
Polypropylene Copolymer® PF7531	Polypropylene	⑩	Translucent	135	0	
Cellgyn® (TPE)	TPE	⑪	Translucent	135	NT	
Polypropylene HS Natural NAV020 WM	Polypropylene	⑫	Translucent	135	0	
EPDM	Ethylene Propylene Diene Monomer	⑬	Opaque	130	-50	

Bio-Ease+® Clamps



Part Number	Size	Dimensions					Material ⑥
		A [in]	B [in]	C [in]	D [in]	E [in]	
13MHHS-075-01	3/4"	2.45	0.93	1.3	2.2	1.10	GL Nylon
13MHHS-150-01	1-1/2"	4.14	0.93	1.73	3.2	1.90	GL Nylon
13MHHS-200-01	2"	4.67	0.93	2.92	3.4	1.90	GL Nylon
13MHHS-300-01	3"	5.79	0.93	4.00	4.0	1.90	GL Nylon
13MHHS-400-01	4"	6.80	0.93	5.08	5.1	1.59	GL Nylon

See Material Tech Table of ⑥ for material specifications.

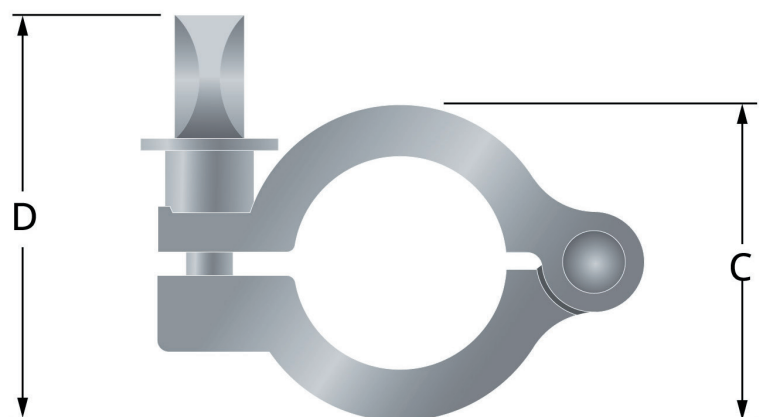
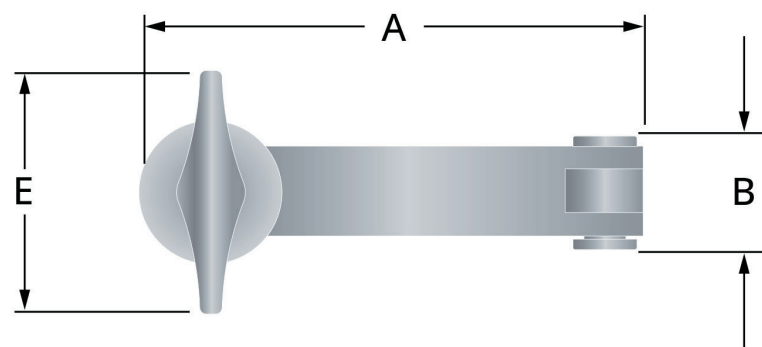

True Union Clamps



Part Number	Size	Dimensions				Material ②
		A [in]	B [in]	C [in]	D [in]	
F-075-TUC	3/4"	0.98	1.50	0.83	1.10	Kynar® PVDF
F-100-TUC*	1" (MAXI)	1.52	2.09	1.06	1.32	Kynar® PVDF
F-150-TUC	1-1/2"	2.00	2.80	1.28	1.51	Kynar® PVDF

*For Sani-Pro® Fittings **ONLY**
See Material Tech Table of ② for material specifications.

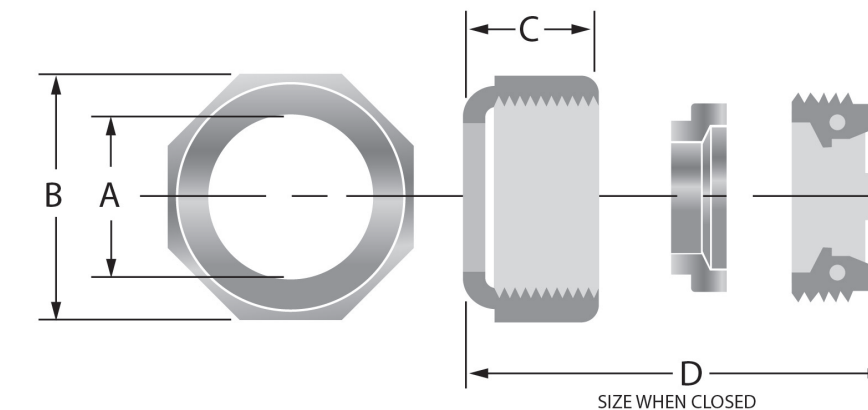

SaniSure® Clamps



Sanitary Gaskets



Part Number	Size	Dimensions		Material ⑥
		OAL [in]	A [in]	
SS-NYB-MINI	3/4" (MINI)	3.51	0.77	GL Nylon
SS-NYB-150	1.5"	6.24	0.77	GL Nylon

(*) General dimension for opened clamp.
See Material Tech Table of ⑥ for material specifications.

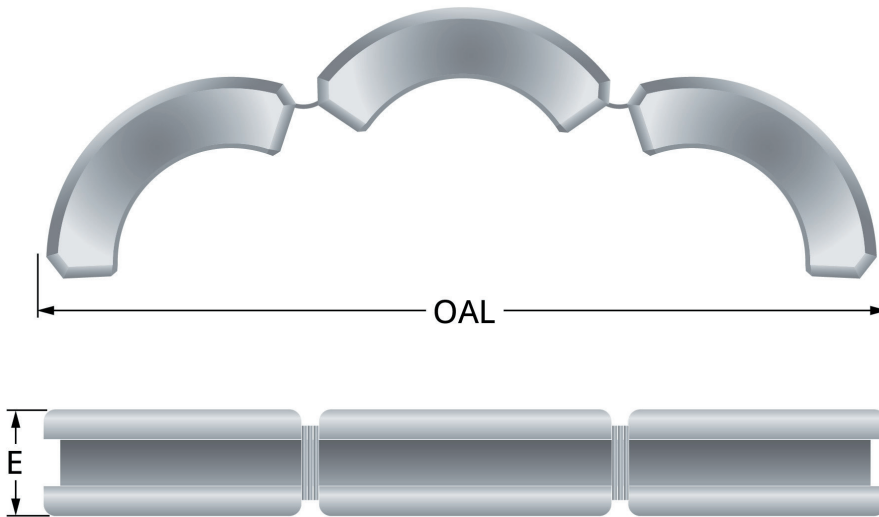

1/2"-3/4"

Part Number	Size	Dimensions			Material
		A [in]	B [in]	C [in]	
42-RXPX-050	1/2"	0.860	0.38	0.797	Platinum Cured Silicone (PCS) ③
42-RXPX-075	3/4"	0.860	0.62	0.797	Platinum Cured Silicone (PCS) ③

1"-4"

Part Number	Size	Dimensions			Material
		A [in]	B [in]	C [in]	
40-RXPX-100	1"	1.984	0.900	1.78	Platinum Cured Silicone (PCS) ③
40-RXPX-150	1.5"	1.984	1.400	1.718	Platinum Cured Silicone (PCS) ③
40-RXPX-200	2.0"	2.515	1.900	2.218	Platinum Cured Silicone (PCS) ③
40-RXPX-250	2.5"	3.050	2.400	2.781	Platinum Cured Silicone (PCS) ③
40-RXPX-300	3.0"	4.682	3.869	4.344	Platinum Cured Silicone (PCS) ③
40-RXPX-400	4.0"	6.507	5.817	6.156	Platinum Cured Silicone (PCS) ③

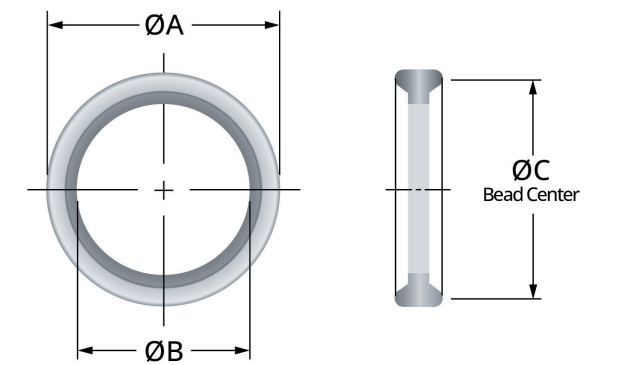

See Material Tech Table of ③ for material specifications.

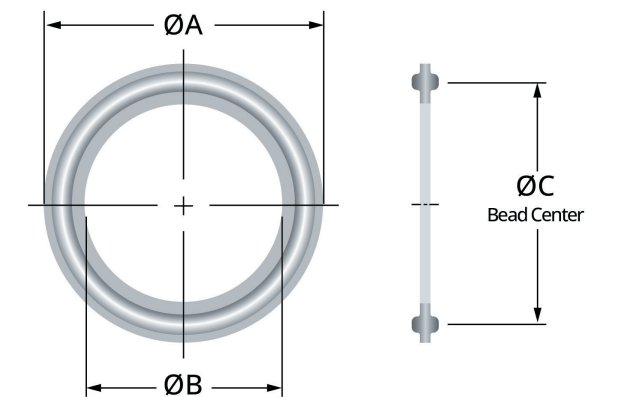

Guage Guard Isolator Diaphragms



Sanitary Tees



Gauge Guard Isolators
Mini 3/4" TC

Part Number	Size	Dimensions		Material
		A [in]	B [in]	
42GGI-E-075	3/4"	0.86	0.797	EPDM ⑬
40GGI-PX-075	3/4"	0.86	0.797	Platinum Cured Silicone ③

Gauge Guard Isolators, Gamma Irradiated
Mini 3/4" TC

Part Number	Size	Dimensions		Material
		A [in]	B [in]	
42GGI-E-075-CP	3/4"	0.86	0.797	EPDM ⑬
42GGI-PX-075-CP	3/4"	0.86	0.797	Platinum Cured Silicone ③

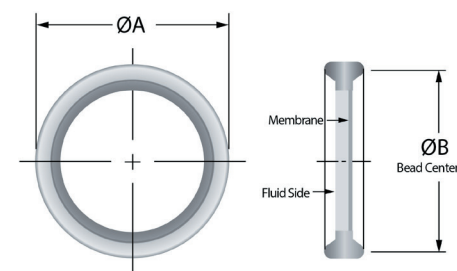

Gauge Guard Isolators
Mini 1-1/2" TC

Part Number	Size	Dimensions		Material
		A [in]	B [in]	
40GGI-E-1501.5	1.5"	1.984	1.718	EPDM ⑬
40GGI-PX-150	1.5"	1.984	1.718	Platinum Cured Silicone ③

Gauge Guard Isolators
Mini 1-1/2" TC

Part Number	Size	Dimensions		Material
		A [in]	B [in]	
40GGI-E-150-CP	1.5"	1.984	1.718	EPDM ⑬
40GGI-PX-150-CP	1.5"	1.984	1.718	Platinum Cured Silicone ③

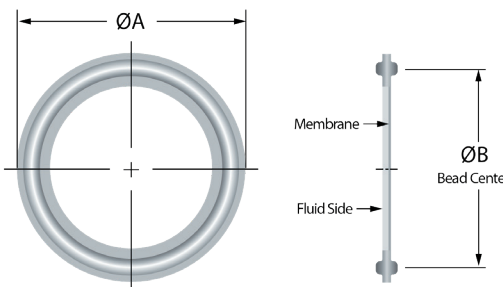

Part Number	Size	Dimensions					Material		
		A [in]	B [in]	C [in]	D [in]	E [in]	Kynar® PVDF ②	Polypropylene P5M6K-080 ①	Polypropylene Profax 7531 ⑩
7MP-075-**	3/4"	5.35	2.62	0.560	0.750	0.992	K	PP	T
7MP-100-**	1"	6.38	3.19	0.856	1.106	1.984	K	PP	T
7MP-150-**	1-1/2"	5.50	2.75	1.356	1.606	1.984	K	PP	T

See Material Tech Table of ①, ②, ⑩ for material specifications.

Materials
 Replace * with T = Polypropylene Profax 7531
 Replace * with K = PVDF (KYNAR®)
 Replace * with PP = Polypropylene P5M6K

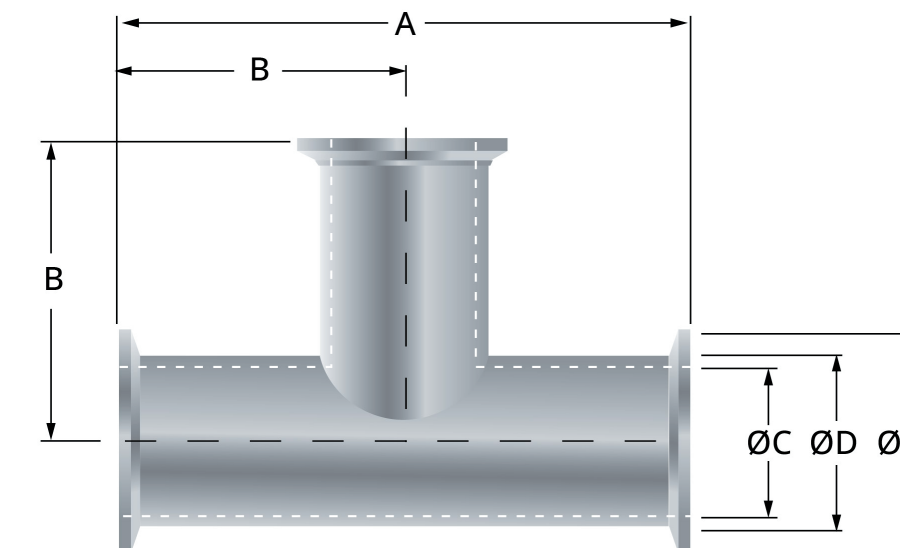

Sanitary Short Bull Tees



Part Number	Size	Dimensions					Material		
		A [in]	B [in]	C [in]	OAH [in]	OAL [in]	Kynar® PVDF ②	Polypropylene Profax 7531 ⑩	Polypropylene P5M6K ①
**SB075	3/4"	0.984	2.62	1.250	2.120	5.210	K	T	PP
**SB100	1"	1.984	3.19	1.3	3.75	6.52	K	T	PP
**SB150	1.5"	1.984	2.75	0.984	3.92	5.490	K	T	PP

See Material Tech Table of ①, ②, ⑩ for material specifications.

Materials

Replace ** with T = Polypropylene Profax 7531
 Replace ** with K = PVDF (KYNAR®)
 Replace ** with PP = Polypropylene P5M6K

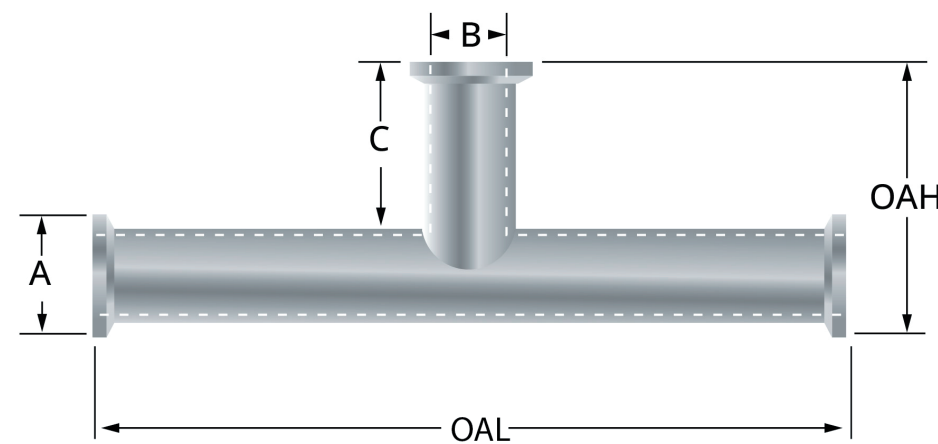

Sanitary 90° Elbows



Part Number	Size	Dimensions					Material		
		A [in]	B [in]	C [in]	D [degree]	AOL [in]	Kynar® PVDF ②	Polypropylene Profax 7531 ⑩	Polypropylene P5M6K ①
**90075	3/4"	0.620	0.750	0.984	90	2.500	K	T	PP
**90100	1"	0.870	1.000	1.984	90	2.750	K	T	PP
**90150	1-1/2"	0.870	1.500	1.984	90	2.750	K	T	PP

See Material Tech Table of ①, ②, ⑩ for material specifications.

Materials

Replace ** with T = Polypropylene Profax 7531
 Replace ** with K = PVDF (KYNAR®)
 Replace ** with PP = Polypropylene P5M6K-080

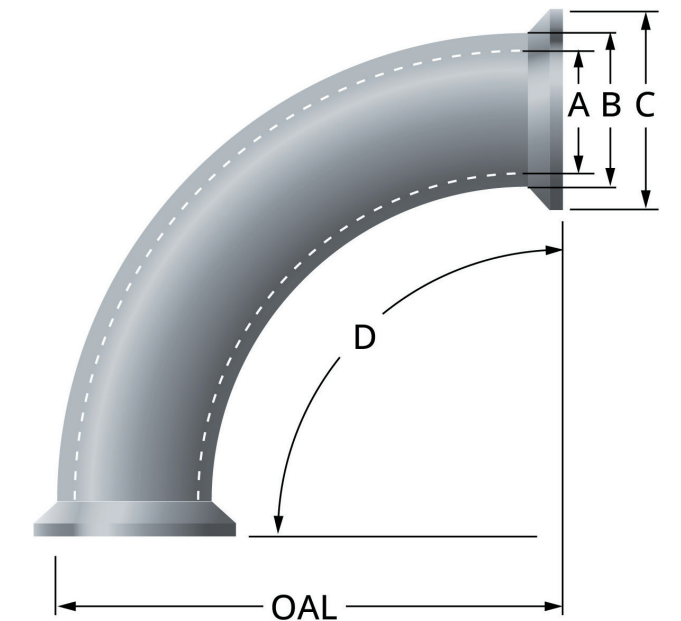

Sanitary Concentric Reducers



Eccentric Reducers

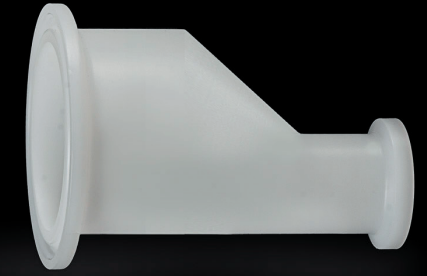

Description	Part Number	OAL (L) [in]	TC1			TC2			Material		
			TC SIZE [in]	TC OD [in]	ID AT TC FACE [in]	TC SIZE [in]	TC OD [in]	ID AT TC FACE [in]	Kynar® PVDF ②	Polypropylene P5M6K-080 ①	Polypropylene Profax 7531 ⑩
1" TC x MINI TC	31-14MP-16L-12-**-**	3.0"	1" Ladish	1.984	0.856	3/4"	0.992	0.62	K	PP	T
1.5" TC x MINI TC	31-14MP-24-12-**-**	3.0"	1-1/2"	1.984	1.358	3/4"	0.992	0.62	K	PP	T
2" TC x MINI TC	31-14MP-32-12-**-**	3.0"	2"	2.516	1.856	3/4"	0.992	0.62	K	PP	T
3" TC x MINI TC	31-14MP-48-12-**-**	3.0"	3"	3.579	2.856	3/4"	0.992	0.62	K	PP	T
1.5" TC x 1" TC	31-14MP-24-16L-**-**	3.0"	1-1/2"	1.984	1.358	1" Ladish	1.984	0.856	K	PP	T
2" TC x 1" TC	31-14MP-32-16L-**-**	3.0"	2"	2.516	1.856	1" Ladish	1.984	0.856	K	PP	T
3" TC x 1" TC	31-14MP-48-16L-**-**	3.0"	3"	3.759	2.856	1" Ladish	1.984	0.856	K	PP	T
2" TC x 1.5" TC	31-14MP-32-24-**-**	3.0"	2"	2.516	1.856	1-1/2"	1.984	1.358	K	PP	T
3" TC x 1.5" TC	31-14MP-48-24-**-**	3.0"	3"	3.579	2.856	1-1/2"	1.984	1.358	K	PP	T
3" TC x 2" TC	31-14MP-48-32-**-**	3.0"	3"	3.579	2.856	2"	1.856	1.856	K	PP	T
4" TC x 3" TC	31-14MP-64-48-**-**	2.36"	4"	4.682	3.835	3"	2.856	2.856	K	PP	T

See Material Tech Table of ①, ②, ⑩ for material specifications.

Materials

Replace ** with T = Polypropylene Profax 7531
 Replace ** with K = PVDF (KYNAR®)
 Replace ** with PP = Polypropylene P5M6K-080

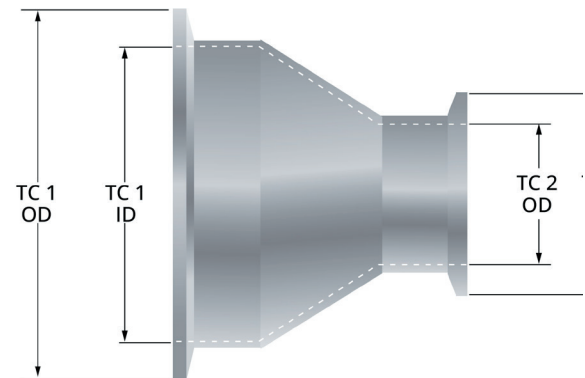

See Material Tech Table of ①, ②, ⑩ for material specifications.

Materials

Replace ** with PP = Polypropylene P5M6K-080
 Replace ** with K = PVDF (KYNAR®)
 Replace ** with T = Polypropylene Profax 7531

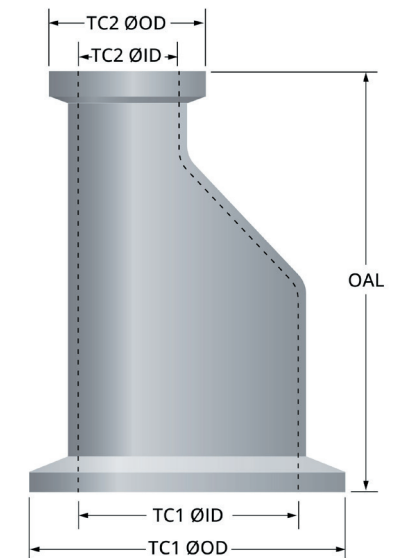

Sanitary End Caps

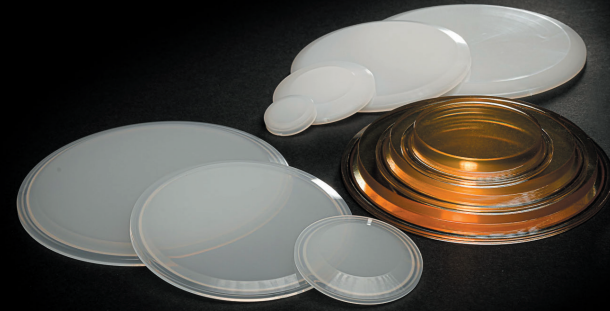

aSURE® Fittings



Sanitary Heavy Duty End Caps

Part Number	Size	Dimensions				Material	
		A [in]	B [in]	C [in]	D [in]	Polypropylene Propylux® ⑫	Polysulfone ④
16AMP-150-**	1-1/2"	1.984	1.718	1.606	0.375	PP	PS
16AMP-200-**	2"	2.515	2.218	2.106	0.375	PP	PS
16AMP-250-**	2-1/2"	3.050	2.781	2.606	0.375	PP	PS
16AMP-300-**	3"	3.579	3.281	3.106	0.375	PP	PS
16AMP-400-**	4"	4.682	4.344	4.106	0.375	PP	PS
16AMP-600-**	6"	6.570	6.156	6.106	0.500	PP	PS
16AMP-800-**	8"	8.570	8.156	8.106	0.500	PP	PS

Sanitary End Caps

Part Number	Size	Dimensions				Material
		A [in]	B [in]	C [in]	D [in]	
TEC-075	3/4"	0.984	0.800	0.750	0.23	ProFax-7531 ⑩
TEC-075-G	3/4"	0.984	0.800	0.750	0.230	P5M6K ①
KEC-075	3/4"	0.984	0.800	0.750	0.230	Kynar® PVDF ②
TEC-150	1-1/2"	1.984	1.718	1.500	0.240	ProFax-7531 ⑩
TEC-150-G	1-1/2"	1.984	1.718	1.500	0.240	P5M6K ①
KEC-150	1-1/2"	1.984	1.718	1.500	0.240	Kynar® PVDF ②
TEC-200	2"	2.516	2.218	2.000	0.230	ProFax-7531 ⑩
TEC-200-G	2"	2.516	2.218	2.000	0.230	P5M6K ①
KEC-200	2"	2.516	2.218	2.000	0.230	Kynar® PVDF ②
TEC-300	3"	3.579	3.281	3.000	0.220	ProFax-7531 ⑩
TEC-300-G	3"	3.579	3.281	3.000	0.220	P5M6K ①
KEC-300	3"	3.579	3.281	3.000	0.220	Kynar® PVDF ②
TEC-400	4"	4.682	4.344	4.000	0.225	ProFax-7531 ⑩
TEC-400-G	4"	4.682	4.344	4.000	0.225	P5M6K ①
KEC-400	4"	4.682	4.344	4.000	0.225	Kynar® PVDF ②

See Material Tech Table of ①, ②, ⑩ for material specifications.

See Material Tech Table of ⑦, ④ for material specifications

Materials
 Replace ** with PP = Polypropylene Propylux®
 Replace ** with PS = Polysulfone

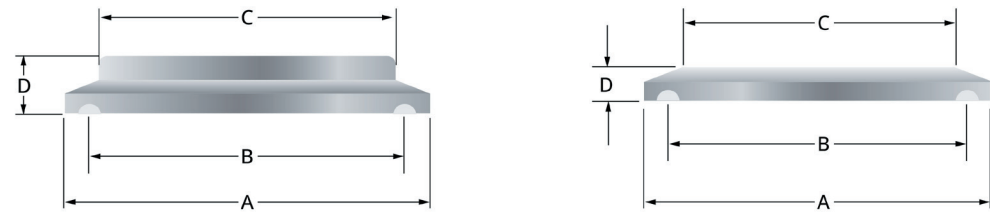

Part Number	TC Size	Barb Size	Dimensions					Material	
			A [in]	B [in]	C [in]	D [in]	E [in]		
F-AS-14MPHR075-125	3/4" TC x 1/8" Mono Barb	3/4"	1/8"	0.992	1.26	0.38	0.15	0.08	Polypropylene P5M6K-080/TPE ①
F-AS-14MPHR075-187	3/4" TC x 3/16" Mono Barb	3/4"	3/16"	0.992	1.26	0.38	0.24	0.08	Polypropylene P5M6K-080/TPE ①
F-AS-14MPHR075-250	3/4" TC x 1/4" Mono Barb	3/4"	1/4"	0.992	1.47	0.29	0.34	0.08	Polypropylene P5M6K-080/TPE ①
F-AS-14MPHR075-375	3/4" TC x 3/8" Mono Barb	3/4"	3/8"	0.992	2.09	0.60	0.46	0.08	Polypropylene P5M6K-080/TPE ①
F-AS-14MPHR075-500	3/4" TC x 1/2" Mono Barb	3/4"	1/2"	0.992	2.09	0.60	0.67	0.08	Polypropylene P5M6K-080/TPE ①
F-AS-14MPHR075-750	3/4" TC x 3/4" Mono Barb	3/4"	3/4"	0.992	1.97	0.61	0.88	0.08	Polypropylene P5M6K-080 ①

Part Number	TC Size	Barb Size	Dimensions					Material	
			A [in]	B [in]	C [in]	D [in]	E [in]		
F-AS-14MPHR150-250	1-1/2" x 1/4" Mono Barb	1-1/2"	1/4"	1.984	2.01	0.37	0.32	0.13	Polypropylene P5M6K-080/TPE ①
F-AS-14MPHR150-375	1-1/2" x 3/8" Mono Barb	1-1/2"	3/8"	1.984	2.07	0.37	0.42	0.13	Polypropylene P5M6K-080/TPE ①
F-AS-14MPHR150-500	1-1/2" x 3/4" Mono Barb	1-1/2"	1/2"	1.984	2.49	0.61	0.66	0.13	Polypropylene P5M6K-080/TPE ①
F-AS-14MPHR150-750	1-1/2" x 3/4" Mono Barb	1-1/2"	3/4"	1.984	2.60	0.64	0.84	0.13	Polypropylene P5M6K-080/TPE ①
F-AS-14MPHR150-1000	1-1/2" x 1-1/2" Mono Barb	1-1/2"	1"	1.984	2.60	0.64	1.08	0.13	Polypropylene P5M6K-080/TPE ①

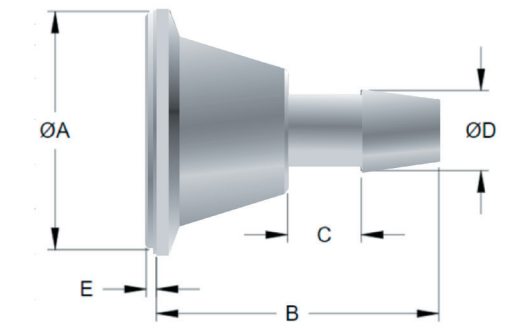

See Material Tech Table of ① for material specifications.

(*) Includes Built-in aSURE® membrane (TPV ⑧ or TPE ⑩)

TC x Monobarb Adapters



Part Number	Description	TC Size	Barb Size	Dimensions				Material		
				A [in]	B [in]	C [in]	D [in]	Kynar® PVDF ②	Polypropylene P5M6K-080 ①	Polypropylene Profax 7531 ⑩
F-TBL-14MPHR075-125**	3/4" (Mini) Tri-Clamp X 1/8" Mono Barb	3/4"	1/8"	0.992	1.16	0.38	0.15	K	PP	T
F-TBL-14MPHR075-187**	3/4" (Mini) Tri-Clamp X 3/16" Mono Barb	3/4"	3/16"	0.992	1.16	0.38	0.24	K	PP	T
F-TBL-14MPHR075-250**	3/4" (Mini) Tri-Clamp X 1/4" Mono Barb	3/4"	1/4"	0.992	1.37	0.29	0.34	K	PP	T
F-TBL-14MPHR075-375**	3/4" (Mini) Tri-Clamp X 3/8" Mono Barb	3/4"	3/8"	0.992	1.99	0.60	0.46	K	PP	T
F-TBL-14MPHR075-500**	3/4" (Mini) Tri-Clamp X 1/2" Mono Barb	3/4"	1/2"	0.992	1.99	0.60	0.67	K	PP	T
F-TBL-14MPHR150-250**	1 1/2" Tri-Clamp X 1/4" Mono Barb	1-1/2"	1/4"	1.984	1.88	0.37	0.32	K	PP	T
F-TBL-14MPHR150-375**	1 1/2" Tri-Clamp X 3/8" Mono Barb	1-1/2"	3/8"	1.984	1.94	0.37	0.42	K	PP	T
F-TBL-14MPHR150-500**	1 1/2" Tri-Clamp X 1/2" Mono Barb	1-1/2"	1/2"	1.984	2.36	0.61	0.66	K	PP	T
F-TBL-14MPHR150-750**	1 1/2" Tri-Clamp X 3/4" Mono Barb	1-1/2"	3/4"	1.984	2.47	0.64	0.84	K	PP	T
F-TBL-14MPHR150-1000**	1 1/2" Tri-Clamp X 1" Mono Barb	1-1/2"	1"	1.984	2.47	0.64	1.08	K	PP	T
F-TBL-14MPHR200-500**	2.0" Tri-Clamp X 1/2" Mono Barb	2"	1/2"	2.515	2.16	0.50	0.60	K	PP	T
F-TBL-14MPHR200-750**	2.0" Tri-Clamp X 3/4" Mono Barb	2"	3/4"	2.515	2.28	0.56	0.85	K	PP	T
F-TBL-14MPHR150-1000**	2.0" Tri-Clamp X 1" Mono Barb	2"	1"	2.515	2.28	0.56	1.10	K	PP	T

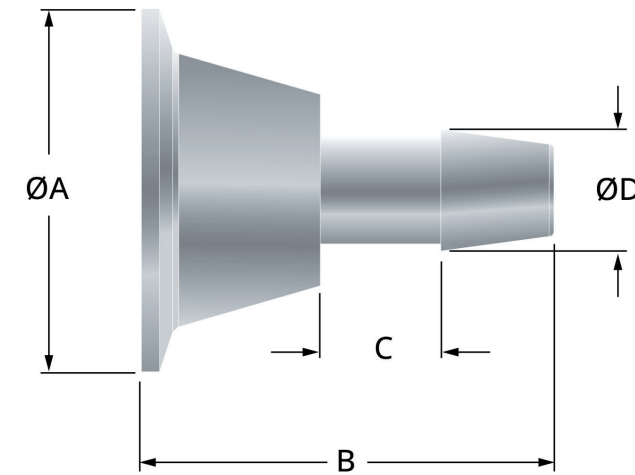

See Material Tech Table of ①, ②, ⑩ for material specifications.

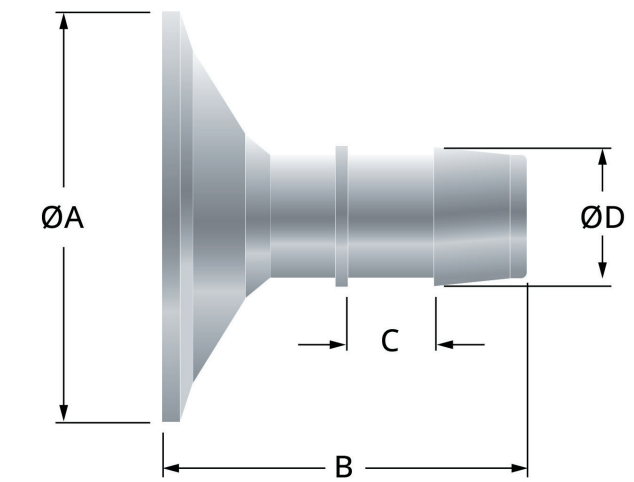

Materials
 Replace ** with PP = Polypropylene P5M6K
 Replace ** with K = PVDF (KYNAR®)
 Replace ** with T = Polypropylene Profax PF7531

Classic Adapter Mono Barbs



Classic Adapter Hose Barbs



Mini Tri-Clamp x Mono Barb

Part Number	Size	Dimensions					Material	
		A [in]	B [in]	C [in]	D [in]	OAL [in]	Kynar® PVDF ②	Polypropylene Profax 7531 ⑩
**ADP-750-04MOB	3/4" Tri-Clamp X 1/4" Mono Barb	0.984	0.62	0.43	0.32	1.66	K	T
**ADP-750-06MOB	3/4" Tri-Clamp X 3/8" Mono Barb	0.984	0.62	0.54	0.45	1.65	K	T
**ADP-750-08MOB	3/4" Tri-Clamp X 1/2" Mono Barb	0.984	0.62	0.55	0.56	1.71	K	T
**ADP-750-12MOB	3/4" Tri-Clamp X 3/4" Mono Barb	0.984	0.62	0.82	0.97	2.43	K	T

See Material Tech Table of ②, ⑩ for material specifications.

1.5" Mini Tri-Clamp x Mono Barb

**ADP-150-04MOB	1 1/2" Tri-Clamp X 1/4" Mono Barb	1.984	1.37	0.43	0.31	2.09	K	T
**ADP-150-06MOB	1 1/2" Tri-Clamp w/ 3/8" Mono Barb	1.984	1.37	0.54	0.45	2.19	K	T
**ADP-150-08MOB	1 1/2" Tri-Clamp w/ 1/2" Mono Barb	1.984	1.37	0.55	0.57	2.29	K	T
**ADP-150-10MOB	1 1/2" Tri-Clamp w/ 5/8" Mono Barb	1.984	1.366	0.68	0.68	2.566	K	T
**ADP-150-12MOB	1 1/2" Tri-Clamp w/ 3/4" Mono Barb	1.984	1.37	0.82	0.97	2.92	K	T

See Material Tech Table of ②, ⑩ for material specifications.

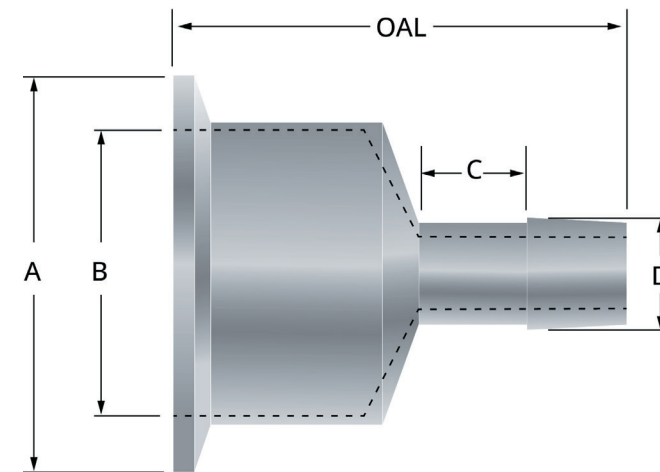

Materials
 Replace ** with K = PVDF (KYNAR®)
 Replace ** with T = Polypropylene Profax PF7531

Mini Tri-Clamp x Hose Barb

Part Number	Size	Dimensions					Material	
		A [in]	B [in]	C [in]	D [in]	OAL [in]	Kynar® PVDF ②	Polypropylene Profax 7531 ⑩
**AD-750-06H	3/4" Tri-Clamp X 3/8" Hose Barb	0.984	0.62	0.12	0.42	1.57	K	T
**AD-750-08H	3/4" Tri-Clamp X 1/2" Hose Barb	0.984	0.62	0.23	0.54	1.66	K	T
**AD-750-10H	3/4" Tri-Clamp X 5/8" Hose Barb	0.984	0.62	0.25	0.63	1.66	K	T

See Material Tech Table of ②, ⑩ for material specifications.

1.5" Mini Tri-Clamp x Hose Barb

**AD-150-06H	1 1/2" Tri-Clamp w/ 3/8" Hose Barb	1.984	1.37	0.2	0.42	2.12	K	T
**AD-150-08H	1 1/2" Tri-Clamp w/ 1/2" Hose Barb	1.984	1.37	0.16	0.55	2.25	K	T
**AD-150-10H	1 1/2" Tri-Clamp w/ 5/8" Hose Barb	1.98	1.37	0.20	0.68	2.25	K	T
**AD-150-12H	1 1/2" Tri-Clamp w/ 3/4" Hose Barb	1.984	1.37	0.22	0.79	2.63	K	T

See Material Tech Table of ②, ⑩ for material specifications.

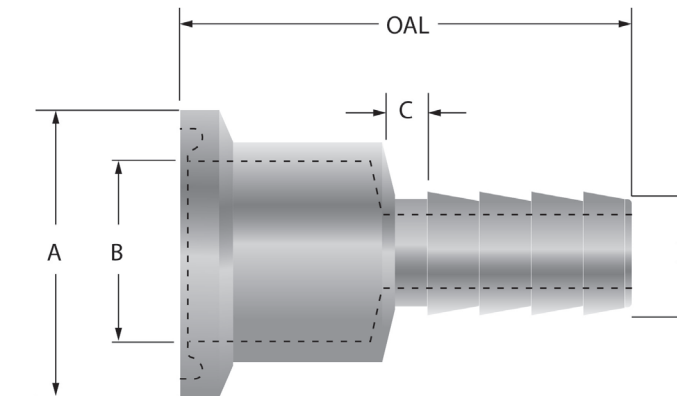

Materials
 Replace ** with K = PVDF (KYNAR)
 Replace ** with T = Polypropylene Profax PF7531

Mini Ferrules



Spool Pieces



Part Number	TC Size	OAL	Dimensions		
			A [in]	B [in]	C [in]
SF-3MM-**	3/4"	0.5	0.118	0.242	0.382
SF-6MM-**	3/4"	0.5	0.236	0.36	0.5
SF-10MM-**	3/4"	0.5	0.394	0.518	0.658
SF-12MM-**	3/4"	0.5	0.472	0.596	0.736

See Material Tech Table of ① ② ⑩ for material specifications.

Materials

Replace ** with PP = Polypropylene P5M6K
 Replace ** with K = PVDF (KYNAR®)
 Replace ** with T= Polypropylene Profax PF7531

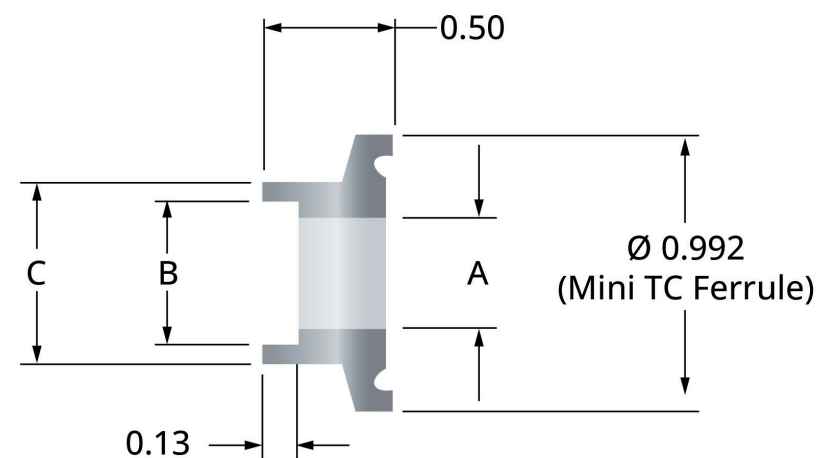

Polypropylene ①

Part Number	Size	Dimensions			
		A [in]	B [in]	C [in]	D (OAL)
12SP**12TC12TC-XX	3/4"	0.992	0.563	0.750	XX
16SP**16TC16TC-XX	1"	1.984	0.856	1.106	XX
24SP**24TC24TC-XX	1-1/2"	1.984	1.356	1.606	XX
32SP**32TC32TC-XX	2"	2.516	1.856	2.101	XX

See Material Tech Table of ① ② ⑩ for material specifications.

Materials

Replace ** with PP = Polypropylene P5M6K
 Replace ** with K = PVDF (KYNAR®)
 Replace ** with T= Polypropylene Profax PF7531

Replace XX with desired length dimension (inches).

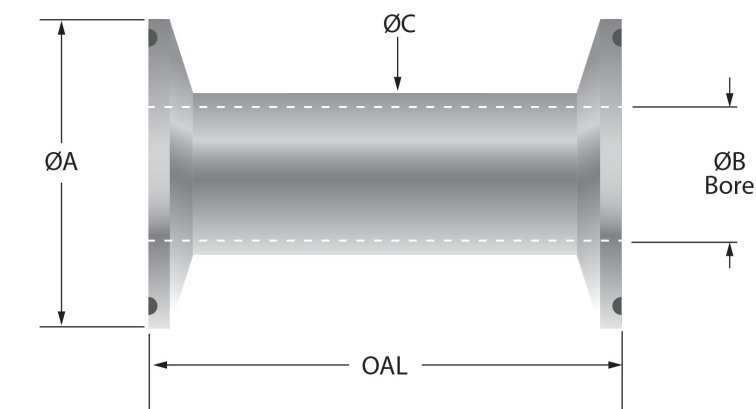

Rigid Pipes



Polysulfone Sight Guages

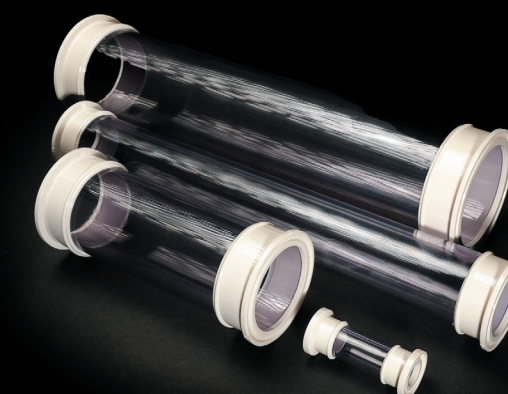

Part Number	Size	Dimensions		
		ID [in]	OD [in]	OAL [ft]
TBL-0750-**-10	3/4"	0.563	0.750	10 ft
TBL-1000-**-10	1"	0.856	1.106	10 ft
TBL-1500-**-10	1-1/2"	1.356	1.606	10 ft
TBL-2000-**-10	2"	1.856	2.101	10 ft
3mm-**-10	3mm	0.118	0.242	10 ft
6mm-**-10	6mm	0.236	0.360	10 ft
10mm-**-10	10mm	0.394	0.518	10 ft
12mm-**-10	12mm	0.472	0.596	10 ft

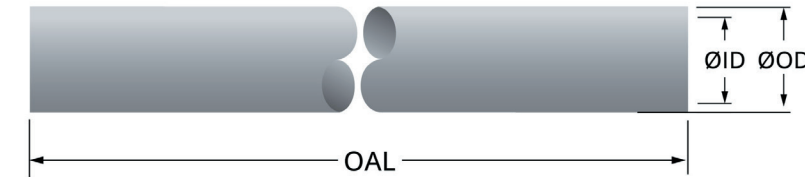

See Material Tech Table of ① ② ⑩ for material specifications.

Materials

Replace ** with PP = Polypropylene P5M6K
 Replace ** with K = PVDF (KYNAR®)
 Replace ** with T = Polypropylene Profax PF7531

Part Number	Size	Dimensions		Material ④
		A [in]	B [in]	
PS075-(OAL)	3/4"	0.992	0.480	Polysulfone ④
PS100L-(OAL)	1"	1.984	0.856	Polysulfone ④
PS150-(OAL)	1-1/2"	1.984	1.356	Polysulfone ④
PS200-(OAL)	2"	2.516	1.856	Polysulfone ④
PS250-(OAL)	2-1/2"	3.047	2.356	Polysulfone ④
PS300-(OAL)	3"	3.579	2.856	Polysulfone ④

See Material Tech Table of ④ for material specifications.

Replace (OAL) with desired length in inches.
 3" minimum, 120" maximum

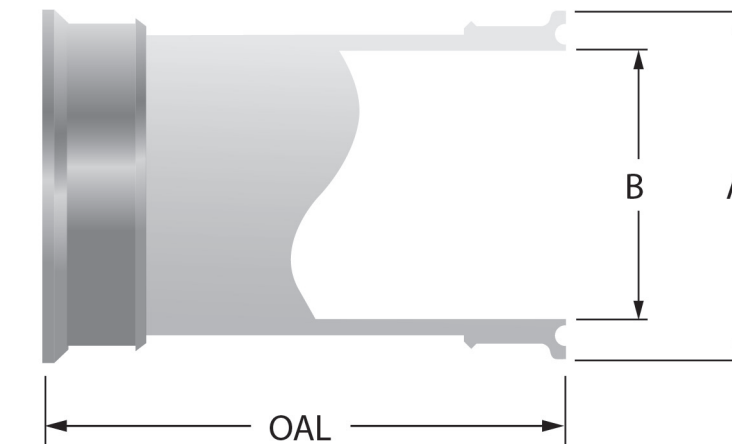

Overmolded Hose Assemblies

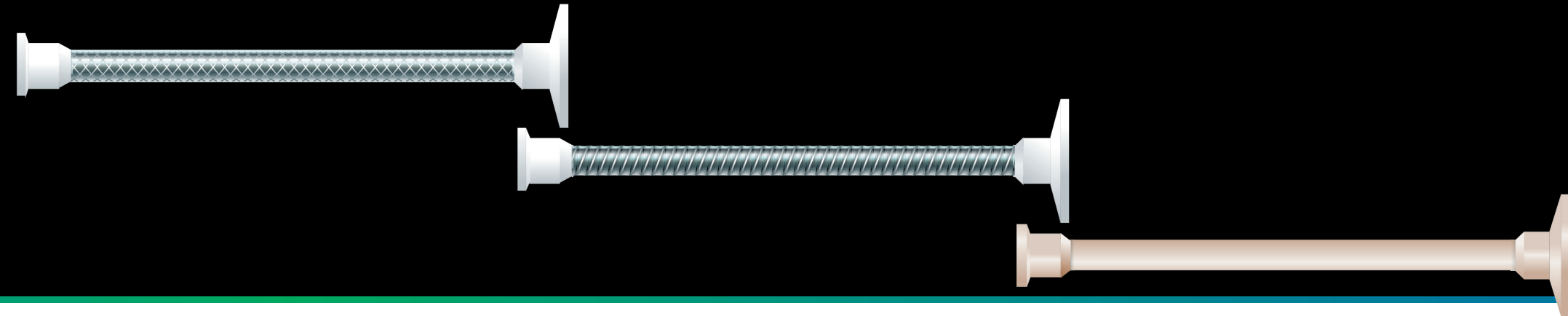

Sample Part Number HFB.04.3.1212-120

HFB = Braided PVC
04 = 1/4" (6.4MM)
3 = 3/32" (2.4MM) WALL **12** = MINI
120 = 120" LENGTH

Sanitary Connections Styles

Mini = 12
 1" (Ladish) = 16
 1-1/2" = 24
 2" = 32
 Plain end = 99

Length

12 = 1 Foot

Bore Inside Diameter

1/4" (6.4 MM) = 04
 3/8" (6.4 MM) = 06
 1/2" (12.7 MM) = 08
 3/4" (19 MM) = 12
 1.0" (25.4 MM) = 16
 1-1/4" (31.75 MM) = 20
 1-1/2" (38.1 MM) = 24

Braided Overmolded Hose Assemblies

Part Number	TC 1 Size	TC 2 Size	ID	OD	Material
HFB04.HW.** *-XX	**	**	1/4"	1/2"	PVC/Braid (7) (9)
HFB06.HW.** *-XX	**	**	3/8"	5/8"	PVC/Braid (7) (9)
HFB08.HW.** *-XX	**	**	1/2"	3/4"	PVC/Braid (7) (9)
HFB12.HW.** *-XX	**	**	3/4"	1-1/8"	PVC/Braid (7) (9)
HFB20.HW.** *-XX	**	**	1-1/4"	1-3/4"	PVC/Braid (7) (9)
HFB24.HW.** *-XX	**	**	1-1/2"	2"	PVC/Braid (7) (9)

Replace XX with desired length dimension.
 Replace ** with desired fitting style

See Material Tech Table of (7) for material specifications.

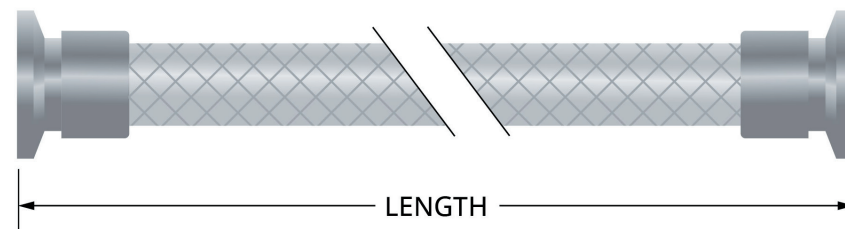

Spring Reinforced Overmolded Hose Assemblies

Part Number	TC 1 Size	TC 2 Size	ID	OD	Material
FVW08.HW.** *-XX	**	**	1/2"	3/4"	PVC/Wire (7) (9)
FVW08.HW.** *-XX	**	**	1/2"	3/4"	PVC/Wire (7) (9)
FVW12.HW.** *-XX	**	**	3/4"	1-1/8"	PVC/Wire (7) (9)
FVW16.HW.** *-XX	**	**	1"	1.609"	PVC/Wire (7) (9)
FVW20.HW.** *-XX	**	**	1-1/4"	1-3/4"	PVC/Wire (7) (9)
FVW24.HW.3** *-XX	**	**	1-1/2"	2"	PVC/Wire (7) (9)

Replace XX with desired length dimension.
 Replace ** with desired fitting style

See Material Tech Table of (7) for material specifications.

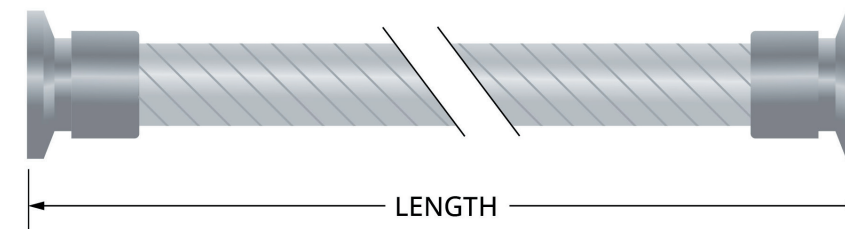

Pharma-Line I Overmolded Hose Assemblies

Part Number	TC 1 Size	TC 2 Size	ID	OD	Material
PHI02.3.** *-XX	**	**	1/8"	5/16"	Pharma-Line (8) (1)
PHI04.4.1** *-XX	**	**	1/4"	1/2"	Pharma-Line (8) (1)
PHI06.3.** *-XX	**	**	3/8"	9/16"	Pharma-Line (8) (1)
PHI08.4.1** *-XX	**	**	1/2"	3/4"	Pharma-Line (8) (1)
PHI08.4.1** *-XX	**	**	1/2"	3/4"	Pharma-Line (8) (1)
PHI10.5.** *-XX	**	**	5/8"	1"	Pharma-Line (8) (1)

Replace XX with desired length dimension.
 Replace ** with desired fitting style

See Material Tech Table of (7) for material specifications.

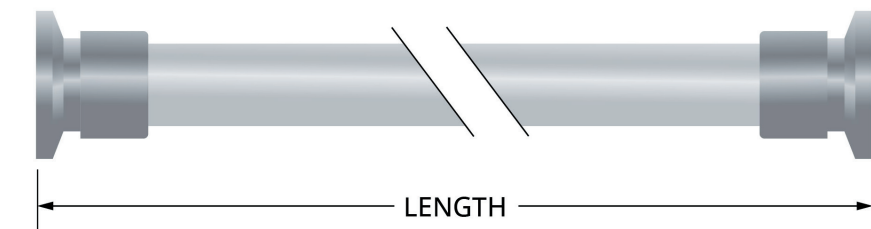

aSure® WFI Samplers



Pinch Clamps



aSURE® WFI Samplers

Cellgyn® TPE Tubing ① ②

Part Number	TC Size [in]	OAL [in]	ID [in]	OD [in]
AS-CGN04.3.1299-18	3/4"	18"	1/4"	7/16"
AS-CGN04.3.1299-36	3/4"	36"	1/4"	7/16"
AS-CGN04.3.2499-18	1-1/2"	18"	1/4"	7/16"
AS-CGN04.3.2499-36	1-1/2"	36"	1/4"	7/16"

See Material Tech Table of ①, ② for material specifications.*

Pharma-Clear® LH Platinum-Cured Silicone Tubing ① ③

Part Number	TC Size [in]	OAL [in]	ID [in]	OD [in]
AS-LH04.3.1299-18	3/4"	18"	1/4"	7/16"
AS-LH04.3.1299-36	3/4"	36"	1/4"	7/16"
AS-LH04.3.2499-18	1-1/2"	18"	1/4"	7/16"
AS-LH04.3.2499-36	1-1/2"	36"	1/4"	7/16"

See Material Tech Table of ①, ③ for material specifications.*

aSURE WFI® Samplers Non-Gamma

Cellgyn® TPE Tubing ① ②

Part Number	TC Size [in]	OAL [in]	ID [in]	OD [in]
ASNG-CGN04.3.1299-18	3/4"	18"	1/4"	7/16"
ASNG-CGN04.3.1299-36	3/4"	36"	1/4"	7/16"
ASNG-CGN04.3.2499-18	1-1/2"	18"	1/4"	7/16"
ASNG-CGN04.3.2499-36	1-1/2"	36"	1/4"	7/16"

See Material Tech Table of ①, ② for material specifications.*

Pharma-Clear® LH Platinum-Cured Silicone Tubing ① ③

Part Number	TC Size [in]	OAL [in]	ID [in]	OD [in]
ASNG-LH04.3.1299-18	3/4"	18"	1/4"	7/16"
ASNG-LH04.3.1299-36	3/4"	36"	1/4"	7/16"
ASNG-LH04.3.2499-18	1-1/2"	18"	1/4"	7/16"
ASNG-LH04.3.2499-36	1-1/2"	36"	1/4"	7/16"

See Material Tech Table of ①, ③ for material specifications.*

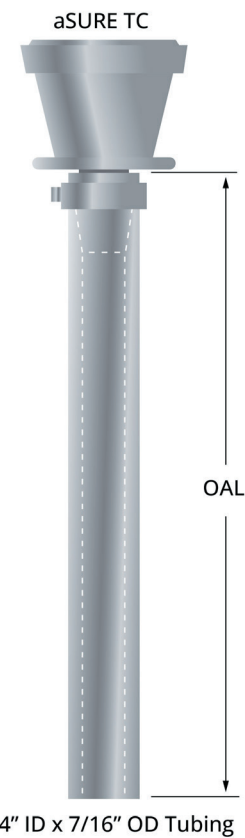

(* See aSURE® Fitting page 16 for more information on aSURE® TC adapters.

Part Number	Description	Dimensions		Material
		OAW [in]	OAL [in]	
340TCSP*	Small Pinch Clamp	0.35	1.00	Polypropylene Profax 7531 ⑩
340P2WG*	Medium Pinch Clamp	0.70	1.50	Polypropylene Profax 7531 ⑩
340TCL*	Large Pinch Clamp	1.00	2.30	Polypropylene Profax 7531 ⑩

See Material Tech Table of ⑩ for material specifications

Colored Feature*

Base part number represents White (e.g. 304TCSP for Small WHITE Pinch Clamp)

Replace * with **R** for Red (i.e. 304TCSPR for Small **RED** Pinch Clamp)
 Replace * with **B** for Blue (i.e. 304TCSPB for Small **BLUE** Pinch Clamp)
 Replace * with **Y** for Yellow (i.e. 304TCSPY for Small **YELLOW** Pinch Clamp)
 Replace * with **G** for Green (i.e. 304TCSPG for Small **GREEN** Pinch Clamp)

*Minimum order quantities apply for colors.

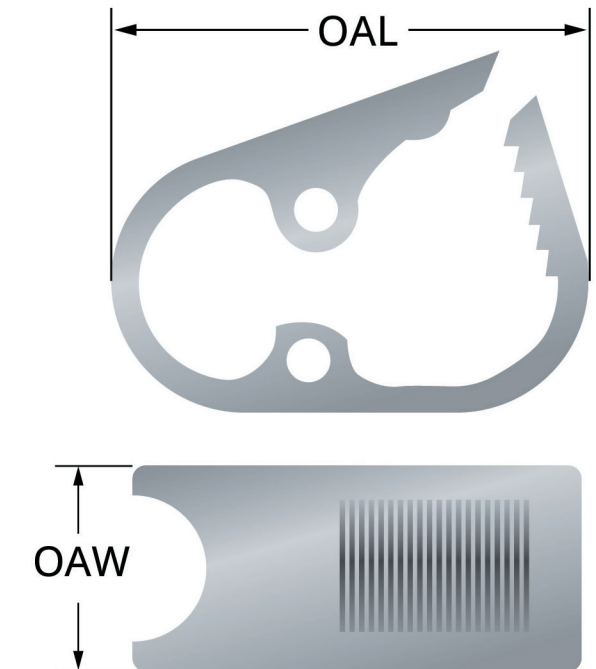

Bio-Ease HD® Clamps

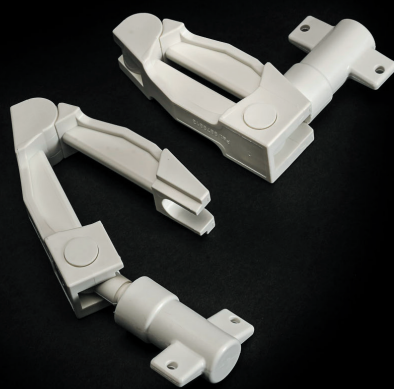

Part Number	Dimensions				Material
	A	B	C	D	
BFS-101	2.4	3.0	0.15	0.8	GL Nylon ⑤

See Material Tech Table of ⑤ for material specifications.

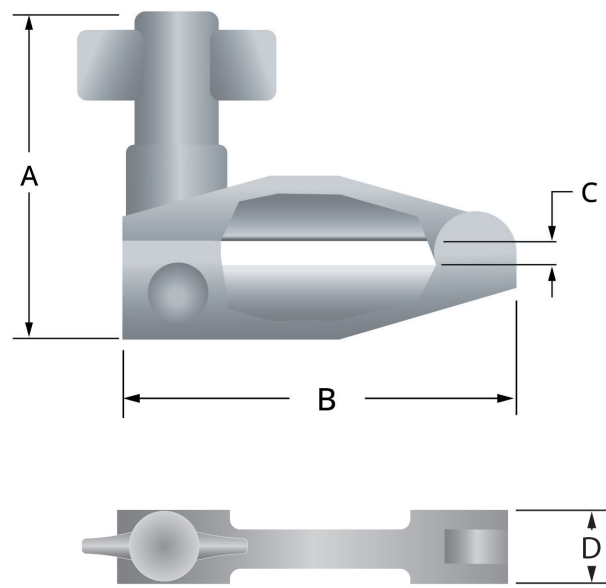

Tube Sinkers



Part Number	Size	Dimensions					Material
		OAL [in]	A [in]	B [in]	C [in]	D [in]	
AC79545S	3/16"	1.28	0.50	0.54	0.17	0.24	Kynar®/ PVDF
AC79548S	1/4"	1.56	0.53	0.57	0.20	0.30	Kynar®/ PVDF
AC79550S	5/16"	1.63	0.63	0.63	0.28	0.36	Kynar®/ PVDF
AC79555S	3/8"	2.56	0.69	1.06	0.34	0.49	Kynar®/ PVDF
AC79560S	1/2"	2.50	0.88	1.01	0.47	0.63	Kynar®/ PVDF
AC79565S	3/4"	3.12	1.13	1.37	0.56	0.85	Kynar®/ PVDF

See Material Tech Table of ② for material specifications.

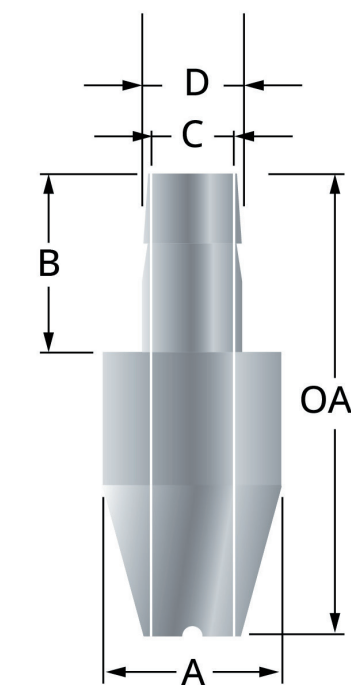

Filling Bells



Part Number	Dimensions					Material
	OAL [mm]	A [mm]	B [mm]	C [mm]	D [mm]	
PIP530	110.00	82.00	77.60	10.00	8.00	Polycarbonate ⑤

See Material Tech Table of ⑤ for material specifications.

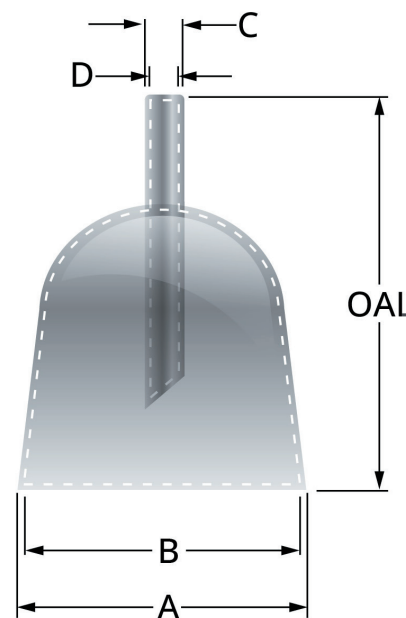

Stir Bars Kynar® PVDF



Gamma Stable (non sterile)

Part Number	Size	Dimensions	
		OAL [in]	A [in]
SS-SB-0851-PVDF	8 X 51	2.00	0.31
SS-SB-1038-PVDF	10 X 38	1.50	0.39
SS-SB-1051-PVDF	10 X 51	2.00	0.39
SS-SB-1080-PVDF	10 X 80	3.15	0.39

Material
KYNAR® PVDF
See Material Tech Table of ② for material specifications.

Sterile

Part Number	Size	Dimensions	
		OAL [in]	A [in]
SS-SB-0851-PVDF-G	8 X 51	2.00	0.31
SS-SB-1038-PVDF-G	10 X 38	1.50	0.39
SS-SB-1051-PVDF-G	10 X 51	2.00	0.39
SS-SB-1080-PVDF-G	10 X 80	3.15	0.39

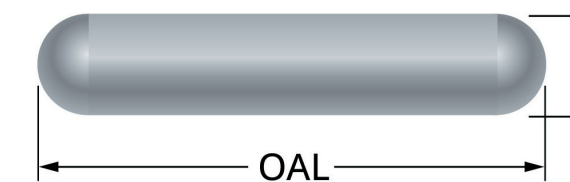

Related Tubing Products [Visit Sanisure.com.](http://Sanisure.com)



Pharma-Clear® 65

We developed our Pharma-Clear® 65 for bulk transfer and general peristaltic-pumping applications. With a slightly higher hardness rating, it has very good resilience and kink resistance and typically has a higher pressure rating than softer alternatives. It also, exhibits superior



Cellgyn®

Cellgyn® TPE tubing is designed specifically for the most demanding bio-pharmaceutical applications. It is ideal for use in peristaltic pumps, single-use assemblies, process filling, and sampling devices and is compatible with all common tube sealers and aseptic tube welders such as Vante, Terumo, BioWelder, GE Sterile Tube Fuser and many more. CellGyn® is exceptionally clear and has superior gas barrier properties and pressure performance vs. silicone tubing.



Pharma-Line™ I

Manufactured from bio-compatible thermoplastic and extruded to precise dimensional tolerances, our Pharm-A-Line I tubing was developed to be compatible with all major peristaltic pumps. Pharm-A-Line™ I provides an excellent alternative to silicone tubing when resistance to chemicals (such as acetone or methylene chloride) is a concern.

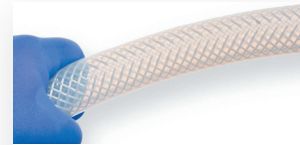

Pharma-Clear® R

Polyester yarn-reinforced, inner braid was developed as a high pressure hose, uses the same compound as our PLTS-65 series tubing, and is tested to the same stringent biological and chemistry standards in order to meet or exceed all EU and USFDA regulations for pharmaceutical use. In addition to pharmaceutical processing, it is commonly used for fine chemicals and



Pharma-Clear® LH

Extruded to precise dimensional tolerances, our Pharma-Clear® LH tubing was developed for critical biopharma applications where longer peristaltic-pump or pinch-valve life, accuracy, and purity are paramount.

SaniSure®

Our Global Footprint



Contact



Americas

1020 Flynn Road
Camarillo, CA 93012
United States
+1-805-920-7264
SalesSupport-US@SaniSure.com

Europe & Asia

ZAE Robert Steichen 16, rue Héierchen
L4940 Bascharage
Grand Duché du Luxembourg
+352-26-33731
SalesSupport-EU@SaniSure.com

Corporate

1020 Flynn Road
Camarillo, CA 93012
United States
+1-805-920-7264
SalesSupport-US@SaniSure.com



Please visit our website
to learn more
sanisure.com

IMPORTANT: It is the user's responsibility to ensure the suitability and safety of SaniSure® products for all intended uses.
For a period of 90 days from the date of delivery, SaniSure® warrants this product to be free from defects in materials and workman- ship.
Our only obligation will be to replace any portion proving defective, or at our discretion, refund the purchase price thereof.
User assumes all other risk, if any, including the risk of injury, loss or damage, direct or consequential, arising out of the use, misuse or inability to use this product.
THIS LIMITED WARRANTY IS IN LIEU OF THE WARRANTIES OF MERCHANTABILITY, FITNESS FOR PARTICULAR PURPOSE AND ALL OTHER WARRANTIES, EXPRESSED OR IMPLIED.
No deviation is authorized. SaniSure® assumes no obligations or liability for any advice furnished by it or for results obtained with respect to those products.
All such advice is given and accepted at the user's risk.
All specifications contained within this document are subject to change without notice.
Please contact our quality department for the most up to date validation and information related to product-qualification.

Authorized Distributor:
Acuity Process Solutions
Web: acuityprocess.com
Phone: 508.809.5099

